

# 3000 psi Self-Sealing Quick Disconnect/3200 Series\*

For hydraulic applications . . . Meets requirements of MIL-C-25427A

FOR TYPE II (-65° F TO +275° F) SYSTEMS

The Aeroquip 3200 Series Self-Sealing Coupling is a reliable quick disconnect for 3000 psi aircraft and missile applications.

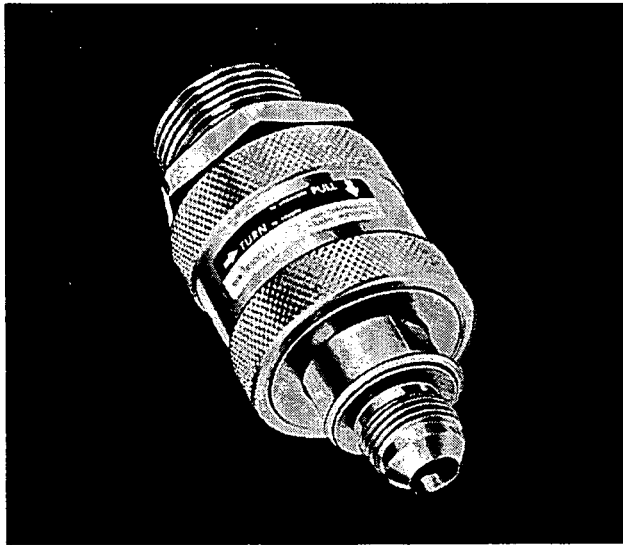

### Advantages:

**Quick Connecting . . .** Easily connects with one hand; disconnects with a straight pull on the Union Nut.

**Positive Action . . .** Valves open simultaneously with the locking action. There is no stable intermediate position where the coupling is partially open and unlocked.

**No Fluid Loss . . .** during connection or disconnection.

**Excludes Air, Dirt, Moisture . . .** No cavity to trap air, dirt, or moisture.

**Simple Construction . . .** only thirteen parts plus "O" rings and Teflon back-up rings. No delicate mechanisms to malfunction.

### Principle of Operation

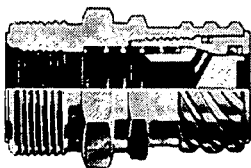

BULKHEAD HALF

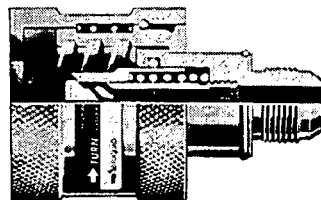

HOSE ATTACHING HALF

**Disconnected Coupling with valves closed.** Note how "O" rings provide unexposed and fully protected seal for poppet and tubular valve sleeve. When connecting, coupling halves align and mate without a cavity, thus preventing air entrapment on connection or fluid spillage on disconnection.

**Fully coupled and locked . . .** valves open. Internal hex in union nut is locked on male body hex. A straight pull of the union nut disengages the lock permitting quick disconnection of the coupling.

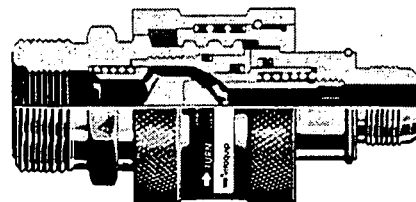

# Style I

## Coupling Styles and Part Numbers

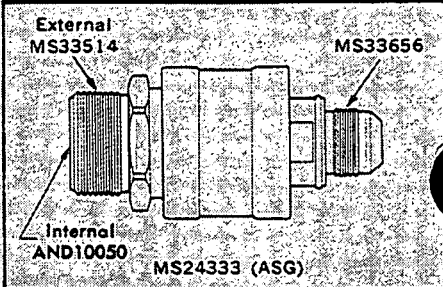

3200 Series Couplings are available for various hydraulic fluids and with all standard end fitting combinations. Select the base part number for coupling halves or coupling assembly from the table at right.

Complete the part number by adding dash size to base number (Example: 3200-8). Couplings for other fluids and end fitting styles are available; write for full information.

Removable, hinged type MS24335 mounting flanges, dust caps, and plugs are available for all sizes. See page 4.

MATERIAL: ALUMINUM

		Application	HYDRAULIC	SKYDROL
PART NUMBERS	Coupling half, Bulkhead mounting		3202	320211
	Coupling Assembly		3200	320016
	Coupling half, Hose attaching		3205	320516

## Coupling Dimensions

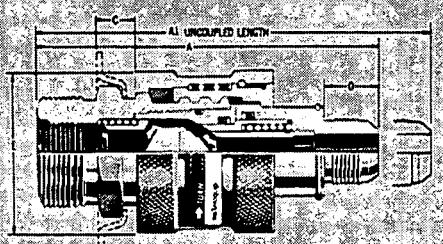

Style I

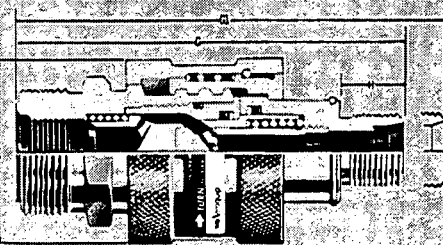

Style II

## Overall Coupling Lengths

Size	I	II	III	IV
— 4	3.175	3.078	3.729	3.554
— 6	3.566	3.469	4.216	4.018
— 8	3.990	3.893	4.673	4.452
— 10	4.640	4.543	5.410	5.176
— 12	4.919	4.799	5.842	5.507
— 16	5.814	5.715	6.719	6.433

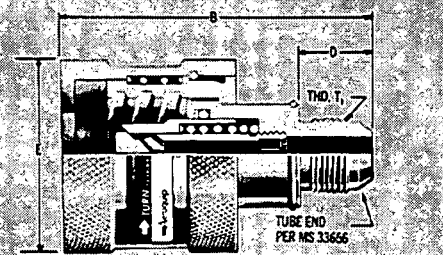

Coupling half, Hydraulic Hose attaching

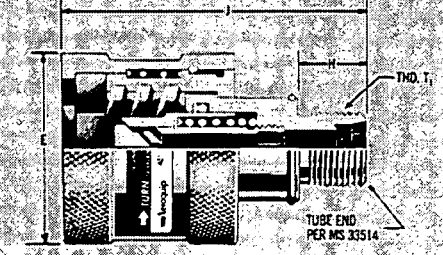

Coupling half, hydraulic Hose attaching

## END FITTING DIMENSIONS

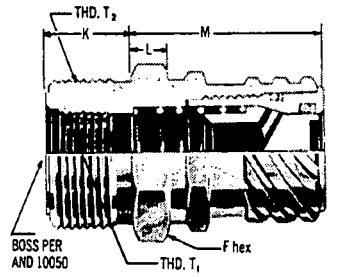

Coupling half, Hydraulic—Bulkhead mounting.

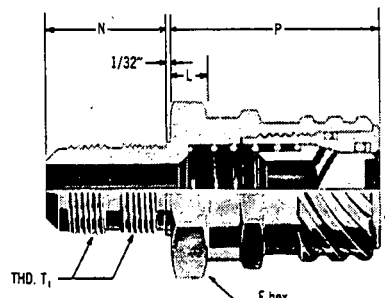

Coupling half, Hydraulic—Bulkhead mounting

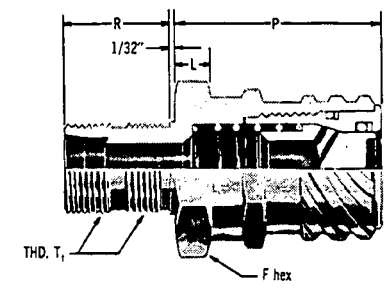

Coupling half, Hydraulic—Bulkhead mounting

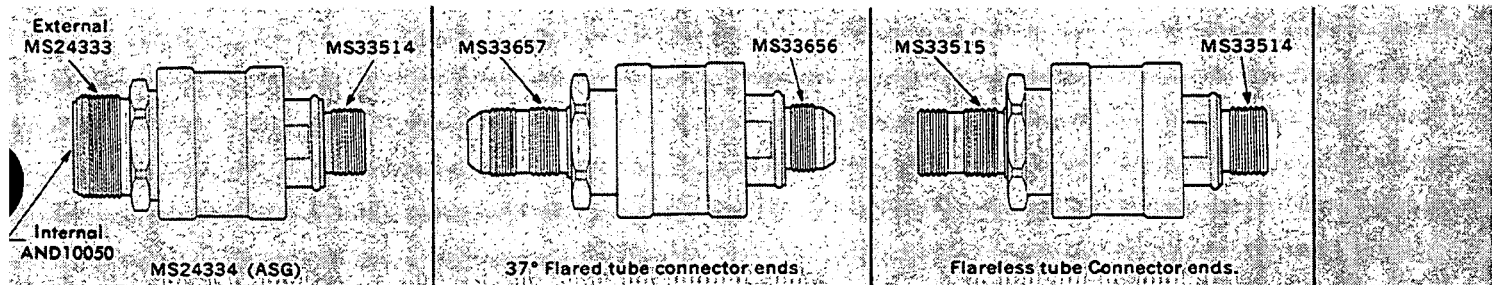

HYDRAULIC	SKYDROL	HYDRAULIC	SKYDROL	HYDRAULIC	SKYDROL
3202	320211	3402	340218	3302	330217
320000	320017	3400	340019	3300	330007
3305	330509	3205	320516	3305	330509

DASH SIZE—	—4	—6	—8	—10	—12	—16
TUBE SIZE	¼"	⅜"	½"	⅝"	¾"	1"
A	3.16	3.57	3.99	4.65	4.93	5.81
*A <sub>1</sub> MAX.	3.77	4.14	4.61	5.34	5.73	6.77
B	2.16	2.59	2.89	3.38	3.48	4.15
D	.550	.556	.657	.758	.864	.911
E dia. MAX.	1.54	1.67	1.89	2.13	2.38	2.63
F hex	1.12	1.38	1.62	1.62	1.88	2.12
G	3.08	3.48	3.89	4.54	4.80	5.72
*G <sub>1</sub> MAX.	3.68	4.06	4.52	5.23	5.58	6.67
H	.453	.469	.562	.625	.688	.688
J	2.07	2.50	2.80	3.27	3.33	4.05
K	.594	.594	.718	.781	.906	.938
L	.26	.26	.26	.26	.32	.32
M MAX.	1.28	1.41	1.60	1.84	1.98	2.51
N	1.016	1.094	1.250	1.391	1.562	1.562
P MAX.	1.40	1.53	1.72	1.96	2.20	2.78
R	.938	.984	1.125	1.266	1.375	1.375
T <sub>1</sub>	⅜-20UNF	⅜-18UNF	⅜-16UNF	⅜-14UNF	1⅜-12UN	1⅜-12UN
T <sub>2</sub>	⅜-14UNF	1⅜-12UN	1⅜-12UN	1⅜-12UN	1⅜-12UN	1⅜-12UN
Style I	.281	.425	.638	.897	1.212	1.811
Style II	.322	.445	.649	.908	1.247	1.858
Style III	.275	.417	.626	.912	1.224	1.901
Style IV	.274	.414	.613	.902	1.199	1.827

\*Dimension with complete separation of coupling halves allowing lateral displacement without interference between coupling halves.

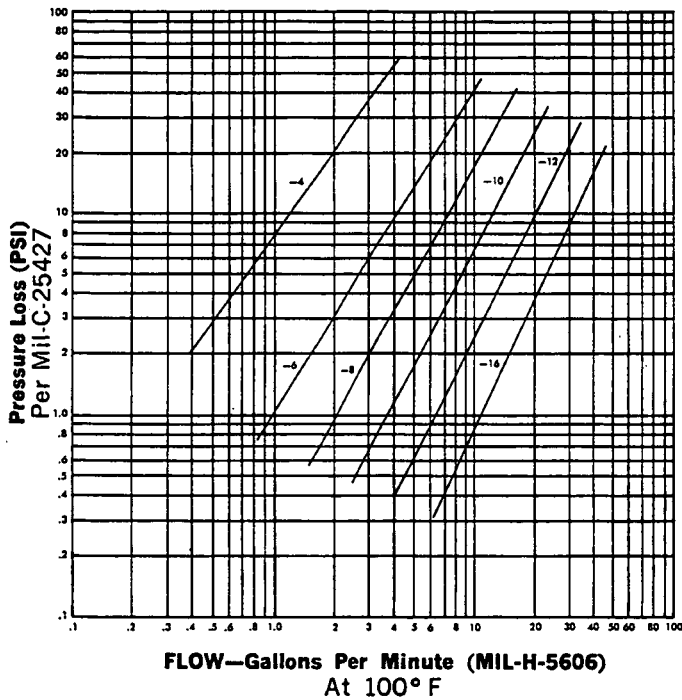

Write for ASB-54—Maintenance and Overhaul Manual on 3200 Series Couplings.

### Pressure loss versus flow

Pressure loss . . . to find the pressure loss for a given coupling size at a given flow rate: 1) find flow rate at bottom of chart and read up until line intersects the curve for the coupling size in question; 2) read across to find the pressure loss.

The Aeroquip 3200 Series Coupling is used wherever a fast, safe connection is needed in 3000 psi hydraulic systems. There is no stable, partially connected position permitting fluid to flow.

3200 Series couplings connect and disconnect with one hand in a single, easy motion. A visual check to verify positive connection is provided by a contrasting color on the locking hex. The positive thread action of the nut provides a mechanical advantage permitting connection against line pressures up to 60 psi.

The coupling may be bulkhead mounted using a jam nut (AN924) or with an optional 4-holed mounting flange (MS 24335).

3200 Series couplings are available with end fitting combinations, materials and packings for other fluid applications and for elevated temperature service. 3200 Series Part No's for Skydrol and MIL-H-5606 for Type II systems (-65° F to +275° F) are listed herein. Write for additional information on 3200 Series couplings to meet your specific requirements.

### Mounting flange

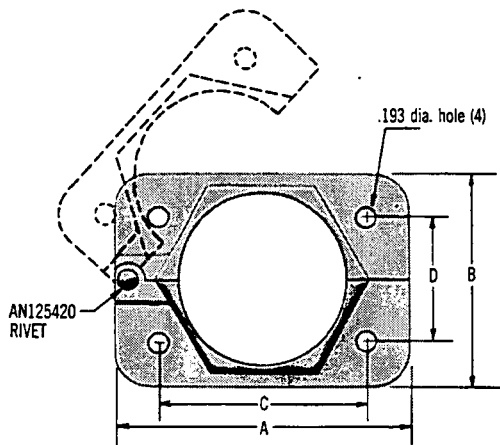

Aeroquip 3222-size/MS24335-size Mounting Flange						
Dash Size	-4	-6	-8	-10	-12	-16
A	2.25	2.50	2.75	2.75	3.00	3.25
B	1.63	1.81	1.94	2.13	2.38	2.63
C	1.52	1.73	1.95	1.95	2.16	2.38
D	.88	1.00	1.13	1.13	1.25	1.38
Wt./lbs	.043	.051	.063	.070	.074	.102

Material: 1010 steel, cadmium plated (QQ-P-416, type II, Class 2)

### Dust Caps and Plugs.

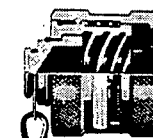

MATERIAL:  
ALUMINUM

CABLE ASSEMBLY

Dust Cap  
Part No. 3207—Size

MATERIAL:  
ALUMINUM



CABLE ASSEMBLY

Dust Plug  
Part No. 3209—Size

**Aeroquip**



Eaton Corporation  
**Aeroquip Group**  
 Engineered Systems Division  
 300 South East Avenue  
 Jackson, Michigan 49203-1972  
 517/787-8121, Fax: 517/787-5758  
[www.aeroquip.com](http://www.aeroquip.com)

Specifications subject to change without notice.  
 Aeroquip products are protected by patents internationally.