

EATON

180°

60°

Aerospace
Fluid Conveyance

Aeroquip® Brand
Ultra-Mate™ Couplings

- The Ultimate in Push-Pull Couplings
- Self-Seal, Self-Locking Couplings
- Automatic Pull-Home Valve Sleeve
- Tactile Locking Pins
- Vacuum to 5000 psi



Patent 6,557,824

Table of Contents

Ultra-Mate™ Couplings	3
Applications	3
Design Features	3
Key Components	4
Dimensions	4
Table: Letter Codes and Tube Sizes	4
Table: Coupling Dimensions	4
Basic Operation & Technical Data	5
Reliability	5
Weight and Performance Characteristics	6
Table: Coupling Statistics	6
Materials	6
Part Numbers (Tables)	
High Pressure 5000 psi, (345 bar) Series	
Coupling Halves, Bulkhead	6
Coupling Halves, Hose Attaching	6
Low Pressure 1500 psi, (103 bar) Series	
Coupling Halves, Bulkhead	7
Coupling Halves, Hose Attaching	7

Introduction

Eaton®'s Aeroquip® brand Ultra-Mate™ couplings are a new generation of self-seal, self-locking, push-pull couplings. They allow quick and easy connection and disconnection of fuel, lube oil, coolant and hydraulic lines for civil and military aircraft as well as ground vehicle applications.

The innovative Ultra-Mate™ automatic pull-home valve sleeve, features a soft seal tubular valve. This valve provides leak-free operation — a critical advantage for personal and environmental safety.

Ball bearings inside the hose half coupling sleeve fit into grooves located in the mating coupling half which, in turn, mechanically pulls the sleeve toward the closed position. It effectively prevents fluid spillage and leakage due to valve sleeve sticking or binding.

Tactile locking pins “pop out” when the connector is securely mated. These locking pins, located on the outer diameter, serve as a secondary locking system. They also provide visual and tactile proof of secure couplings — a valuable asset when coupling access is restricted.

Ultra-Mate™ couplings are available in corrosion resistant steel, titanium, or aluminum for applications with operating pressures up to 5,000 psi (345 bar).

Ultra-Mate™ features include:

- A leak-free seal during connection and disconnection
- Locking pins located on the outer diameter that provide a tactile and visual confirmation of full connection and act as a secondary locking system
- A low pressure drop across the connector — up to 45% improvement over current coupling models on the market
- Minimal air inclusion during connection and disconnection
- A small envelope design
- Lighter weight — up to 36% lighter compared to previous push-pull couplings

Every Ultra-Mate™ coupling design and manufacture has undergone rigorous quality and performance testing. This dedication to detail and excellence is what has made the Eaton Aeroquip® brand a leader in the aerospace industry.

Applications

The Ultra-Mate™ coupling has a zero-leakage, ultra low design for use in hydraulic, fuel, lube oil and coolant systems on a variety of civil aircraft, military aircraft and ground defense vehicles. The design of the coupling is essentially the same for all fluid applications; however, the O-ring material varies to accommodate the different fluids and their respective properties. For low-pressure applications, aluminum components are typically selected over stainless steel due to their lower cost and weight. In addition, for low-pressure systems or systems which do not experience high vibration, customers can select an Ultra-Mate™ coupling without tactile locking pins and consequently gain a smaller profile coupling and reduce system weight.

Design Features

The Ultra-Mate™ coupling is a self-sealing, self-locking coupling that allows for quick and easy connection and disconnection of fluid lines. The patented push-pull design features a positive pull-home sleeve, tactile locking pins, and a soft seal tubular valve.

The Ultra-Mate™ coupling has a zero-leakage, low air-inclusion and fluid loss design, which features a flat-faced valve that eliminates air trapped between the two halves during connection.

The unique one-piece design also eliminates a seal and a potential leak path found in older, two-piece designs. The use of a bonded, elastomeric seal on the hose half valve provides a more reliable, leak-free seal when compared to both metal-to-metal or Teflon® seals.

The pull-home sleeve is an important design feature aimed at reducing leakage. As the user begins to disconnect the two coupling halves, small bearings mechanically pull the valve sleeve towards the closed

position to seal off all fluid flow, and release the valve sleeve just before the coupling assembly is fully disconnected.

This revolutionary design has been tested in field applications and in Eaton test facilities to simulate a broad range of working environments. All sizes are qualified to SAE AS1709 and AS7413 requirements for fluid conveyance applications. Ultra-Mate™ couplings can operate at pressures ranging from vacuum to 5,000psi (345 bar) and temperatures ranging from -65°F to +275°F (-54°C to +135°C), giving it unsurpassed versatility for a push-pull coupling.

The Ultra-Mate™ coupling is available in many different end-fitting configurations, and each coupling is leak-tested after assembly to ensure quality.



Ultra-Mate™ couplings have been selected for the Lockheed Martin, Northrop Grumman F-16 Block 60 in the radar coolant system.



Ultra-Mate™ couplings have been selected for the Lockheed Martin F-35 Joint Strike Fighter for all hydraulic, fuel, and coolant applications.

Teflon® is a registered trademark of Dupont Corp.

Key Components

Valve

The valve is a flush face design engineered to minimize air inclusion during connection and disconnection. A bonded seal provides additional leak protection. The valve sleeve first forms a primary seal with the molded o-ring before ending in a metal-to-metal seal.

Ball Bearings

Ball bearings resting in channels in the hose half coupling's internal diameter mechanically pull the valve sleeve towards the closed position and release just before the coupling has been completely disconnected. This is a key feature, which virtually eliminates fluid loss during connection and disconnection.

Indicator

Indicator pins serve as the tactile and visual indication that the two

coupling halves are fully connected. Indicator pins also serve as a secondary locking device that must be pushed in to allow coupling disconnection. Pins are located on opposite sides of the hose half outer diameter.

Arc Latch

The Aeroquip® brand "Arc Latch" locking design provides contact over a broad surface area. This permits low unit loading and helps prevent undue wear of the locking surface. In addition, the wider surface contact contributes to a more effective locking action and provides the coupling with greater capability to withstand high vibration-born environments.

Adapter

There are several possible end-fitting configurations based on application and customer specification.

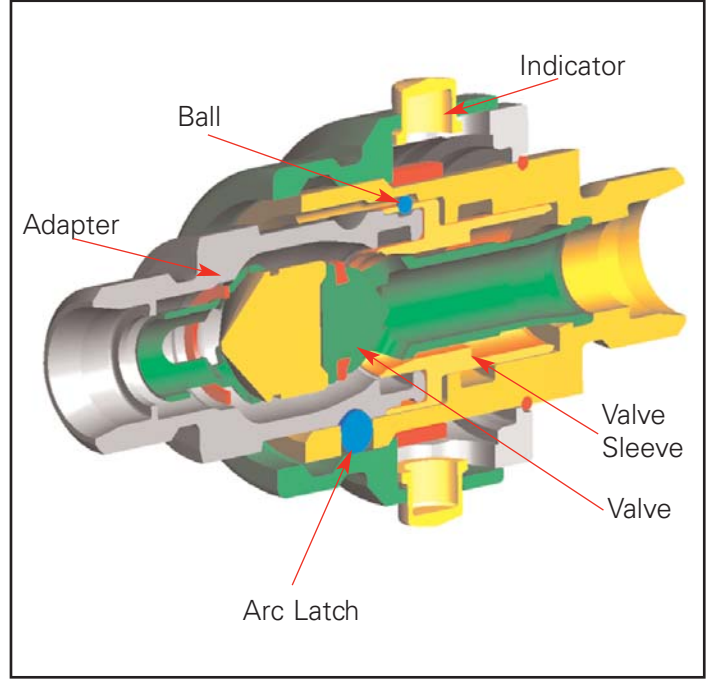
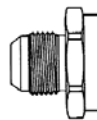

Table: Letter Code & Tube Size

Dash Size	-4	-6	-8	-10	-12	-16
Tube Size (in)	1/4	3/8	1/2	5/8	3/4	1
Letter Code	E	G	H	J	K	M

MS33656
Flared



MS33657
Flared Bulkhead

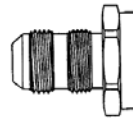

MS33514
Flareless

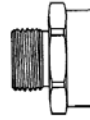

MS33515
Flareless Bulkhead

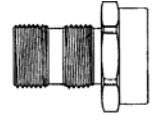

*Arcseal™ end-fitting style also available

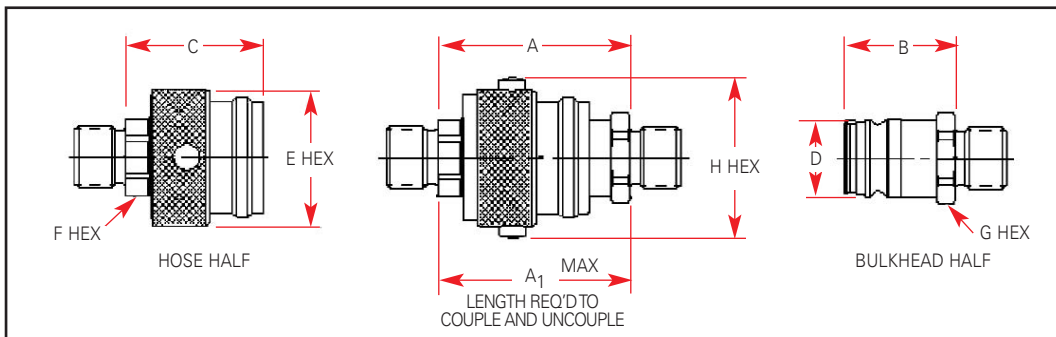

Table: Coupling Dimensions

Dash Size	"A" DIM (IN)	"A1" DIM (IN)	"B" DIM (IN)	"C" DIM (IN)	"D" DIM (IN)	"E" DIM (IN)	"F" HEX (IN)	"G" HEX (IN)	"H" MAX (IN)
-4	1.695	2.150	1.015	1.120	0.552	1.050	0.438	0.625	1.240
-6	1.770	2.310	1.030	1.269	0.687	1.250	0.625	0.750	1.460
-8	2.000	2.530	1.100	1.418	0.843	1.400	0.750	0.938	1.620
-10	2.280	2.820	1.310	1.620	1.048	1.600	0.938	1.063	1.790
-12	2.600	3.400	1.490	1.893	1.227	1.760	1.063	1.313	1.980
-16	3.000	3.910	1.765	2.130	1.493	2.140	1.375	1.563	2.360

Basic Operation and Technical Data

The Ultra-Mate™ coupling, when connected, allows fluid to flow freely from one half to the other. It can provide power or can transfer resources such as coolant or fuel safely and efficiently throughout a system.

The design of the Ultra-Mate™ coupling allows for easy connection and disconnection using only one hand. To connect, simply push the two mating halves together until they click. Both the “clicking” sound as well as the visual and tangible presence of the indicator pins signal that the coupling is secure.

To disconnect the Ultra-Mate™ coupling halves, depress the locking pins and pull straight back. Pulling back on the outer sleeve during disconnection will also aid in this process.



Reliability

Each coupling has been tested at Eaton's state-of-the-art facility. These tests have been designed to simulate all possible working conditions to certify the superior performance of the couplings. The Ultra-Mate™ couplings have been tested to meet or exceed SAE AS1709 specifications for hydraulic push-pull couplings and AS7413 for fuel push-pull couplings. These requirements include:

- Ability to operate within a temperature range of -65°F (-54°C) to +275°F (135°C).
- Capable of enduring 200 connect/disconnect cycles without evidence of malfunction, leakage or damage.
- Ability to tolerate a one-minute proof pressure test equal to 150% of the operating pressure and a burst test equal to 250% of the rated operating pressure without rupture or loss of fluid.
- Ability to withstand a 20g impact test without indication of disconnection, leakage or malfunction.



As the user begins to disconnect the two coupling halves, the small bearings mechanically pull the valve sleeve towards the closed position. This feature virtually eliminates the common problem of valves sticking in the open position.



Once the two coupling halves have been disconnected, the tactile locking pins will lie flush with the outer diameter of the coupling. This indicates that the coupling is no longer securely coupled.

Ultra-Mate™ Pressure Drop Curves

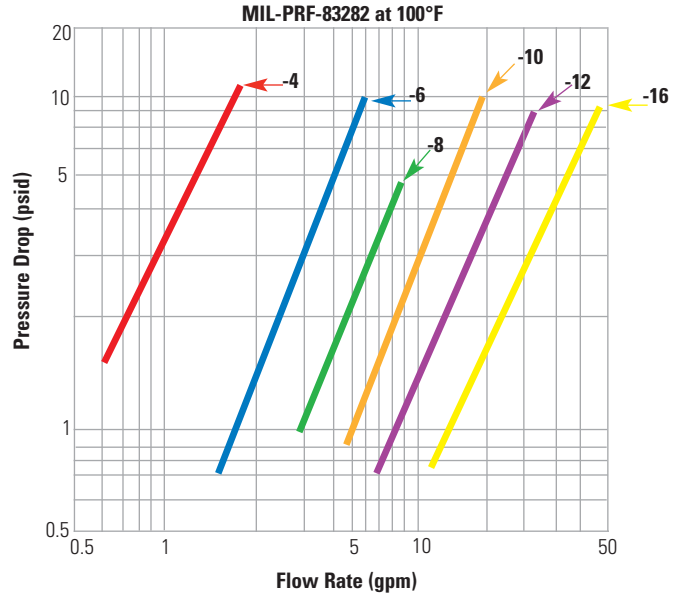

FLOW COEFFICIENT (C_v FACTOR)

(Flow Rate in GPM of WATER 60 F with 1 psig Pressure Drop)

Size	-4	-6	-8	-10	-12	-16
C _v	0.53	1.6	4.1	6.2	10.3	15.9

Ultra-Mate™ Bulletin Weights

**Weight - Aluminum
(1,500 psig)
AS4395 Ends**

**Weight - Cres (5,000 psig)
AS4395 Ends**

**Weight - Titanium
(4,000 psig)
AS4207B Arcseal™ Ends**

Dash Size	Bulkhead Half (lbs)	Hose Half (lbs)	Bulkhead Half (lbs)	Hose Half (lbs)	Bulkhead Half (lbs)	Hose Half (lbs)
-4	.022	.057	.055	.113	.031	.090
-6	.035	.098	.087	.180	.049	.140
-8	.054	.143	.131	.278	0.67	.204
-10	.092	.232	.225	.439	.119	.296
-12	.134	.290	.348	.634	.176	.439
-16	.206	.454	.527	1.033	.296	.725

Weight and Performance Characteristics

Eaton's Ultra-Mate™ couplings have been developed to deliver unsurpassed value to every specific application it is used in. Every coupling is subjected to 100% inspection for critical dimensions as well as leakage and performance. Eaton's statistical process control procedures track these measures, ensuring that quality is part of every step.

Materials

High Pressure Series

Primary Component Material:

Stainless Steel (consult Eaton for Titanium) Media : MIL-PRF-83282 Oil, and Phosphate Ester Base Fluids (Skydrol®)

Packings: Nitrile, EPR

Temperature Range*: -65°F (-54°C) to +275°F (135°C)

Operating Pressure: 5,000psi (345 bar)

Proof Pressure: 7,500psi (517 bar)

Burst Pressure (min): 12,500psi (862 bar)

Low Pressure Series

Primary Component Material: Aluminum

Media: Fuel, MIL-PRF-83280 Oil, Phosphate Ester Base Fluids (Skydrol), PAO

Packings: Nitrile, EPR, Fluorosilicone, Fluorocarbon

Temperature Range*: -65°F (-54°C) to +275°F (135°C)

Operating Pressure: 1,500psi (103 bar)

Proof Pressure: 2,250psi (155 bar)

Minimum Burst Pressure (min): 3,750psi (258 bar)

*With appropriate change in materials and packings, coupling may be adapted to a wide range of fluids and temperatures.

Part Numbers

Eaton is dedicated to helping you choose the right coupling and the right materials for the right application. Our technical service representatives can assist you in part selection. **This catalog features standard coupling models; however, Eaton will provide custom designed couplings upon request.**

High Pressure 5,000 psi Series Coupling Part Numbers

Coupling Halves, Bulkhead

AS33514 Ends			AS4395 Ends			AS4207B (Arcseal™) Ends		
Size	Fluid		Size	Fluid		Size	Fluid	
	MIL-H-83283 Oil	Skydrol		MIL-H-83283 Oil	Skydrol		MIL-H-83283 Oil	Skydrol
-4	AE73535E	AE73609E	-4	AE73611E	AE73613E	-4	AE73615E	AE73617E
-6	AE73535G	AE73609G	-6	AE73611G	AE73613G	-6	AE73615G	AE73617G
-8	AE73535H	AE73609H	-8	AE73611H	AE73613H	-8	AE73615H	AE73617H
-10	AE73535J	AE73609J	-10	AE73611J	AE73613J	-10	AE73615J	AE73617J
-12	AE73535K	AE73609K	-12	AE73611K	AE73613K	-12	AE73615K	AE73617K
-16	AE73535M	AE73609M	-16	AE73611M	AE73613M	-16	AE73615M	AE73617M

AS33515 Ends			AS4396 Ends			AS4208B (Arcseal™) Ends		
Size	Fluid		Size	Fluid		Size	Fluid	
	MIL-H-83283 Oil	Skydrol		MIL-H-83283 Oil	Skydrol		MIL-H-83283 Oil	Skydrol
-4	AE73619E	AE73620E	-4	AE73621E	AE73622E	-4	AE73623E	AE73624E
-6	AE73619G	AE73620G	-6	AE73621G	AE73622G	-6	AE73623G	AE73624G
-8	AE73619H	AE73620H	-8	AE73621H	AE73622H	-8	AE73623H	AE73624H
-10	AE73619J	AE73620J	-10	AE73621J	AE73622J	-10	AE73623J	AE73624J
-12	AE73619K	AE73620K	-12	AE73621K	AE73622K	-12	AE73623K	AE73624K
-16	AE73619M	AE73620M	-16	AE73621M	AE73622M	-16	AE73623M	AE73624M

High Pressure 5,000 psi Series Coupling Part Numbers

Coupling Halves, Hose Attaching

With Tactile/Locking Pins

AS33514 Ends			AS4395 Ends			AS4207B (Arcseal™) Ends		
Size	Fluid		Size	Fluid		Size	Fluid	
	MIL-H-83283 Oil	Skydrol		MIL-H-83283 Oil	Skydrol		MIL-H-83283 Oil	Skydrol
-4	AE73534E	AE73610	-4	AE73612E	AE73614	-4	AE73616E	AE73618E
-6	AE73534G	AE73610	-6	AE73612G	AE73614	-6	AE73616G	AE73618G
-8	AE73534H	AE73610	-8	AE73612H	AE73614	-8	AE73616H	AE73618H
-10	AE73534J	AE73610	-10	AE73612J	AE73614	-10	AE73616J	AE73618J
-12	AE73534K	AE73610	-12	AE73612K	AE73614	-12	AE73616K	AE73618K
-16	AE73534M	AE73610	-16	AE73612M	AE73614	-16	AE73616M	AE73617M

With Visual Indicator Only

AS33514 Ends			AS4396 Ends			AS4208B (Arcseal™) Ends		
Size	Fluid		Size	Fluid		Size	Fluid	
	MIL-H-83283 Oil	Skydrol		MIL-H-83283 Oil	Skydrol		MIL-H-83283 Oil	Skydrol
-4	AE73625E	AE73626E	-4	AE73627E	AE73628E	-4	AE73629E	AE73630E
-6	AE73625G	AE73626G	-6	AE73627G	AE73628G	-6	AE73629G	AE73630G
-8	AE73625H	AE73626H	-8	AE73627H	AE73628H	-8	AE73629H	AE73630H
-10	AE73625J	AE73626J	-10	AE73627J	AE73628J	-10	AE73629J	AE73630J
-12	AE73625K	AE73626K	-12	AE73627K	AE73628K	-12	AE73629K	AE73630K
-16	AE73625M	AE73626M	-16	AE73627M	AE73628M	-16	AE73629M	AE73630M

Low Pressure 1,500 psi Series Coupling Part Numbers

Coupling Halves, Bulkhead

AS33514 Ends					AS4395 Ends				
Size	Fluid				Size	Fluid			
	MIL-PRF-83282 Oil	Phosphate Ester	MIL-PRF-87252	Fuel		MIL-PRF-83282 Oil	Phosphate Ester	MIL-PRF-87252	Fuel
-4	AE73639E	AE73641E	AE74534E	AE74542E	-4	AE73643E	AE73645E	AE75246E	AE75247E
-6	AE73639G	AE73641G	AE74534G	AE74542G	-6	AE73643G	AE73645G	AE75246G	AE75247G
-8	AE73639H	AE73641H	AE74534H	AE74542H	-8	AE73643H	AE73645H	AE75246H	AE75247H
-10	AE73639J	AE73641J	AE74534J	AE74542J	-10	AE73643J	AE73645J	AE75246J	AE75247J
-12	AE73639K	AE73641K	AE74534K	AE74542K	-12	AE73643K	AE73645K	AE75246K	AE75247K
-16	AE73639M	AE73641M	AE74534M	AE74542M	-16	AE73643M	AE73645M	AE75246M	AE75247M

AS33515 Ends					AS4396 Ends				
Size	Fluid				Size	Fluid			
	MIL-PRF-83282 Oil	Phosphate Ester	MIL-PRF-87252	Fuel		MIL-PRF-83282 Oil	Phosphate Ester	MIL-PRF-87252	Fuel
-4	AE73651E	AE73652E	AE74540E	AE74548E	-4	AE73653E	AE73654E	AE74541E	AE74549E
-6	AE73651G	AE73652G	AE74540G	AE74548G	-6	AE73653G	AE73654G	AE74541G	AE74549G
-8	AE73651H	AE73652H	AE74540H	AE74548H	-8	AE73653H	AE73654H	AE74541H	AE74549H
-10	AE73651J	AE73652J	AE74540J	AE74548J	-10	AE73653J	AE73654J	AE74541J	AE74549J
-12	AE73651K	AE73652K	AE74540K	AE74548K	-12	AE73653K	AE73654K	AE74541K	AE74549K
-16	AE73651M	AE73652M	AE74540M	AE74548M	-16	AE73653M	AE73654M	AE74541M	AE74549M

Low Pressure 1,500 psi Series Coupling Part Numbers

Coupling Halves, Hose Attaching

With Tactile Indicator Pins

AS33514 Ends					AS4395 Ends				
Size	Fluid				Size	Fluid			
	MIL-PRF-83282 Oil	Phosphate Ester	MIL-PRF-87252	Fuel		MIL-PRF-83282 Oil	Phosphate Ester	MIL-PRF-87252	Fuel
-4	AE73640E	AE73642E	AE74536E	AE74544E	-4	AE73644E	AE73646E	AE74539E	AE74547E
-6	AE73640G	AE73642G	AE74536G	AE74544G	-6	AE73644G	AE73646G	AE74539G	AE74547G
-8	AE73640H	AE73642H	AE74536H	AE74544H	-8	AE73644H	AE73646H	AE74539H	AE74547H
-10	AE73640J	AE73642J	AE74536J	AE74544J	-10	AE73644J	AE73646J	AE74539J	AE74547J
-12	AE73640K	AE73642K	AE74536K	AE74544K	-12	AE73644K	AE73646K	AE74539K	AE74547K
-16	AE73640M	AE73642M	AE74536M	AE74544M	-16	AE73644M	AE73646M	AE74539M	AE74547M

With visual indicator only.

AS33514 Ends					AS4396 Ends				
Size	Fluid				Size	Fluid			
	MIL-PRF-83282 Oil	Phosphate Ester	MIL-PRF-87252	Fuel		MIL-PRF-83282 Oil	Phosphate Ester	MIL-PRF-87252	Fuel
-4	AE73647E	AE73648E	AE74535	AE74543	-4	AE73649E	AE73650E	AE75244E	AE75245E
-6	AE73647G	AE73648G	AE74535	AE74543	-6	AE73649G	AE73650G	AE75244G	AE75245G
-8	AE73647H	AE73648H	AE74535	AE74543	-8	AE73649H	AE73650H	AE75244H	AE75245H
-10	AE73647J	AE73648J	AE74535	AE74543	-10	AE73649J	AE73650J	AE75244J	AE75245J
-12	AE73647K	AE73648K	AE74535	AE74543	-12	AE73649K	AE73650K	AE75244K	AE75245K
-16	AE73647M	AE73648M	AE74535	AE74543	-16	AE73649M	AE73650M	AE75244M	AE75245M

The user should carefully observe the precautions listed in this catalog or brochure, including the recommendations on the selection of couplings on the relevant pages and the pages on fluid compatibility. Maximum application operating pressure should not exceed operating pressure listed.

WARNING: Application considerations must be observed in selecting appropriate components for the application of these products contained herein. The failure to follow the recommendations set forth in this catalog may result in an

unstable application, which may result in serious personal injury or property damage.

EATON OR ANY OF ITS AFFILIATES OR SUBSIDIARIES SHALL NOT BE SUBJECT TO AND DISCLAIMS ANY OBLIGATIONS OR LIABILITIES (INCLUDING BUT NOT LIMITED TO ALL CONSEQUENTIAL INCIDENTAL AND CONTINGENT DAMAGES) ARISING OUT OF BREACH OF CONTRACT OR OF WARRANTY OR ARISING FROM TORT CLAIMS (INCLUDING WITHOUT LIMITATION NEGLIGENCE AND STRICT LIABILITY) OR OTHER THEORIES OF

LAW WITH RESPECT TO ANY COUPLING ASSEMBLY NOT PRODUCED FROM GENUINE EATON COMPONENTS AND ASSEMBLED IN CONFORMANCE USING GENUINE EATON COMPONENTS WITH THE PROCESS AND PRODUCT INSTRUCTIONS SET FORTH HEREIN.

Eaton Corporation
Fluid Conveyance
300 South East Avenue
Jackson, Michigan 49203-1972
Phone: (517) 787-8121
Fax: (517) 787-5758

Eaton Corporation
Fluid Conveyance
Meadowbrook Road
P.O. Box 819
Toccoa, Georgia 30577-0819
Phone: (706) 779-3351
Fax: (706) 779-2638

Eaton Corporation
Fluid Conveyance
2500 W. Argyle St.
P.O. Box 1845
Jackson, Michigan 49202-1845
Phone: (517) 787-8121
Fax: (517) 789-4716

Eaton LTD
Fluid Conveyance
Posttack 1026
Carl -Benz-Strasse 9
D-82205 Gilching
Germany
Phone: (49) 810-575-0
Fax: (49) 810-575-27

Eaton LTD
Fluid Conveyance
Chemin De Pau
64121 Serres-Castet
France
Phone: (33) 559-333-864
Fax: (33) 559-333-865

Eaton LTD
Fluid Conveyance
Broad Ground Road
Lakeside
Redditch
Worcs B98 8YS
England
Phone: (44) 152-751-7555
Fax: (44) 152-751-7556

www.aerospace.eaton.com

